

cuttingstation

Model Number SS7

Patent Pending*

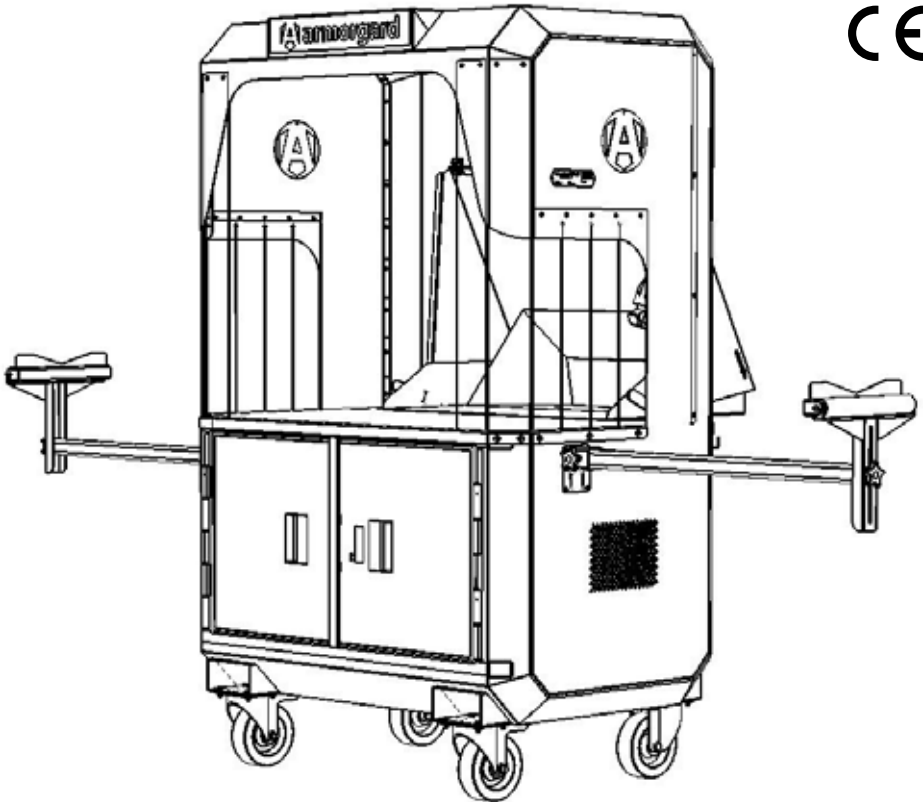

Instruction manual for your
Armorgard CuttingStation

» Welcome...

to your Armorgard CuttingStation, a new way of operating your cutting on site. Designed to reduce noise, reduce dust and increase safety while cutting.

Please read this safety manual carefully prior to operating the CuttingStation

Contents

Welcome	page 2
Safety Information	page 3
Fitting castor wheels	page 4
Swarf collector Installation	page 5
Removeable blanking plate	page 5
Manipulating the support arms	page 6
Extending or retracting the rear panel	page 7
Electricity guide	page 8
Electricity usage	page 9
Air filtration and dust extraction	page 10







***European Patent Application Number EP17183824.6;
European Community Design Registration Number 004511525**



If you have any questions on setting up your CuttingStation, please call 023 9238 0280



Safety Information

-  All relevant PPE must be worn.
-  Apply both brakes whilst cutting.
-  Do not use a dust extraction system whilst cutting aluminium.
-  All electrical parts must be PAT tested at least every 3 months.
-  Relevant fire extinguishers must be nearby whilst cutting.
-  Take care when moving the rear panel as it can present a finger trap hazard.

This Pack includes:

1x CuttingStation
1x Swarf collector
2x M6 nut and bolts
1x 110V power inlet

1x Castor kit with fixing plates
1x Rubber mat
1x Internal light
2x 110V power outlets

» Technical Specification

Product Code	SS7
Power Inlet	16a 110V
Power Outlet	16a 110V (x2)
Wiring	1.5mm Arctic cable
Net Weight	174kg
Weight Load Capacity	800kg
Weight Load Capacity (per arm)	50kg

Fitting castor wheels

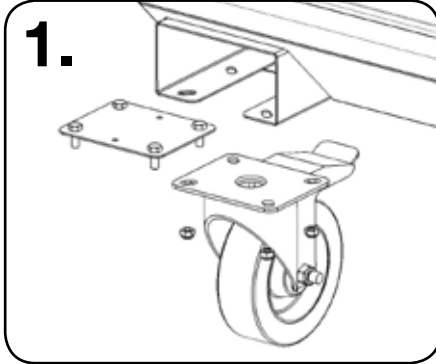

Fix castors using the castor plates, wheels, and nylocks provided. Slide the castor plate into the forklift skid and drop the welded bolts on bolts through the pre-drilled holes in the skid.

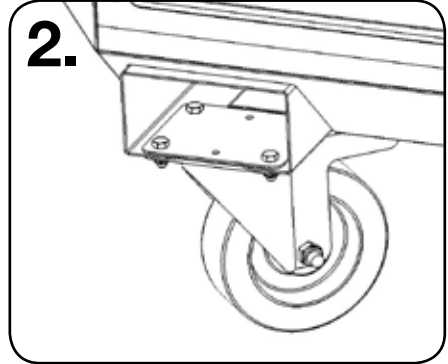

Locate the castor wheel on the bolts of the castor plate, and then tighten all nylocks, ensuring they are fully on the thread of the bolt.

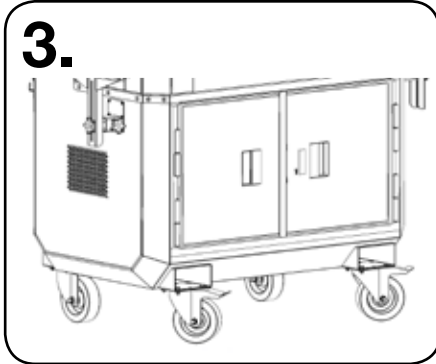

We recommend you position the two swivel-braked castors so they are at the front of the unit, and the two swivel castors at the rear.

Swarf Collector Installation

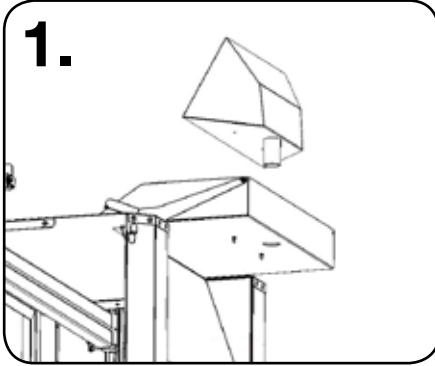

1. Position the swarf collector in the centre hole at the back of the work bench, and fix in place using the 2x M6 bolts provided.

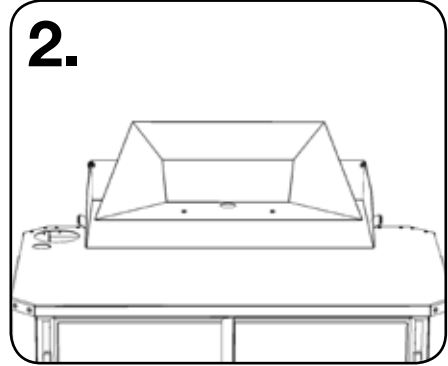

2. Swarf can be collected using a bucket beneath the chute or fine dust (e.g wood) can be collected using an M or H rated dust extractor.

Removeable blanking plate

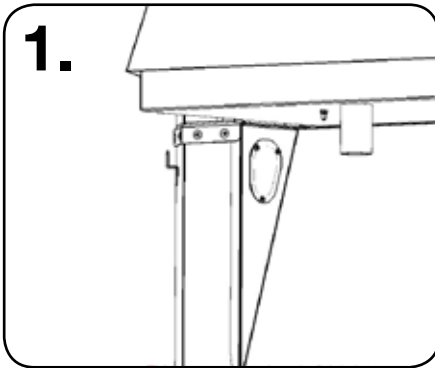

1. At the rear of the CuttingStation is a blanking plate that can be removed to allow cables, extraction hoses etc to be fed into the cabinet beneath the work surface

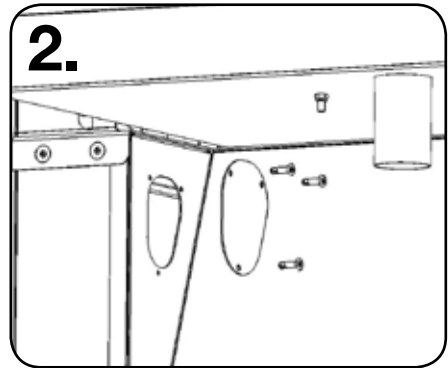

2. The plate can be removed and refixed with the three screws.

Manipulating the support arms

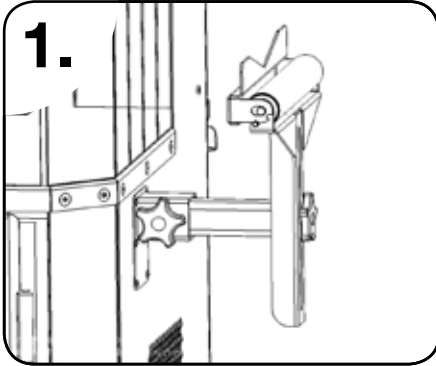

1. The two locking screws on the support arm can be loosened to allow the support arm to slide in and out, and up and down.

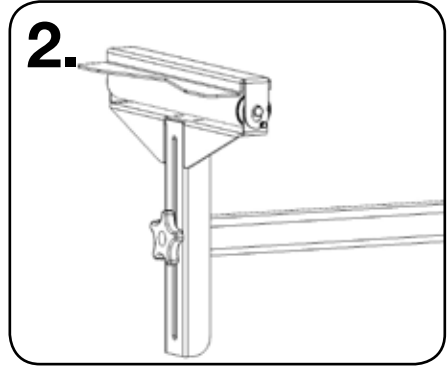

2. The support arm can be configured to have a flat support rest. We do not recommend extending the arms further than 800mm from the main unit.

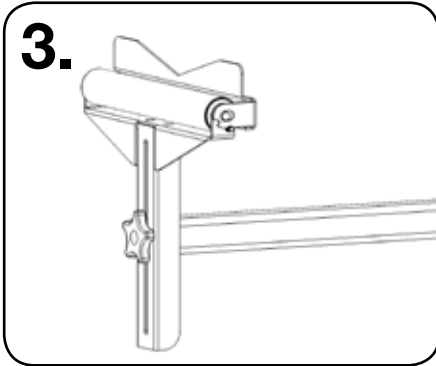

3. The support arm head can be turned 90 degrees for a v-shaped support to hold round materials. Note that in this position the flat surface can also be used as a stop for efficient cutting.

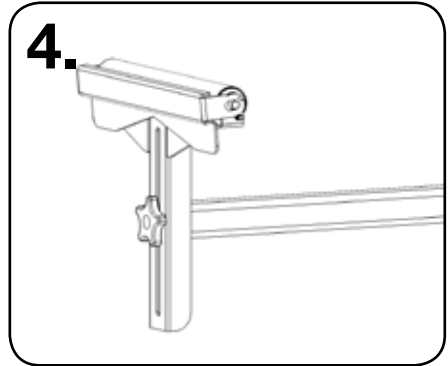

4. The last configuration is a roller, to enable materials to be repositioned easily while being supported at the same time.

Extending or retracting the rear panel

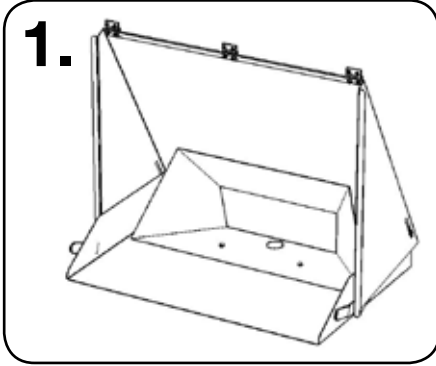

The adjustable back panel can be extended out from the CuttingStation to provide a deeper cutting space.

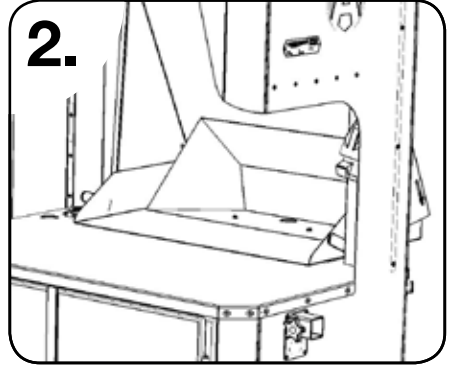

To extend or retract the panel, lift the handle on either side of the swarf collector and push or pull in the direction required.

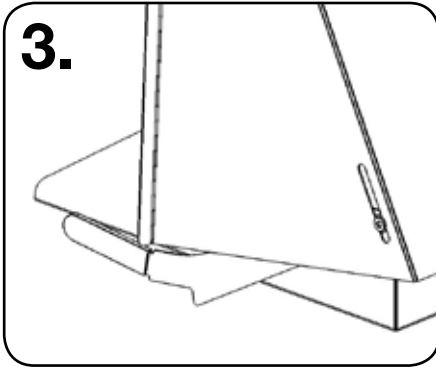

When the back panel is extended, the handles on either side drop down to lock it in position.

Electricity guide

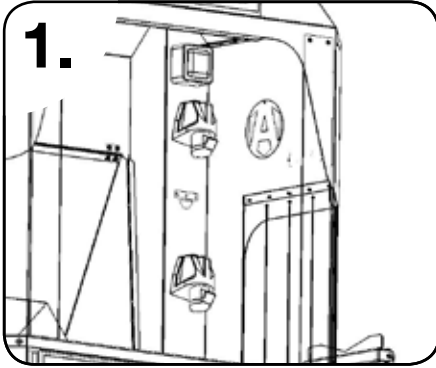

There are 2x 110V sockets located inside the CuttingStation on the right.

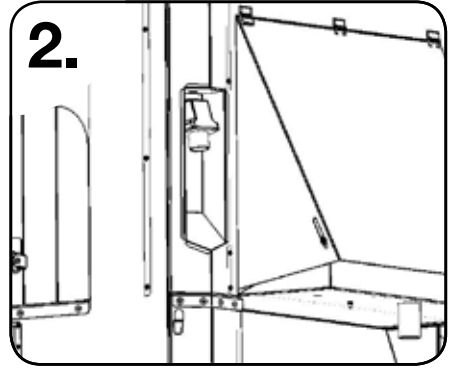



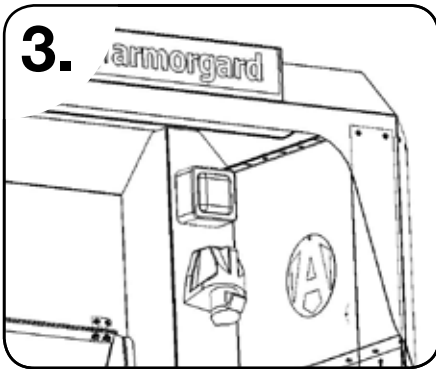

The electricity sockets and overhead light only function when connected to a power supply. They can be connected using the recessed 110V inlet socket on the rear, right-hand corner.



Inside the CuttingStation a switch is located in the top right corner for operating the work light.

Electricity Usage

-  **WARNING:** Electricity can kill. Ensure you are working in a safe environment at all times.
-  Do not plug extension leads into the sockets provided on the CuttingStation as this could result in the electricity unit overheating.
-  Before use, ensure that all sockets are undamaged and free from water, dirt, oil and any other foreign objects.
-  Take necessary precautions to prevent cables from becoming a hazard.
-  The electricity sockets should only be used to power suitable 110V equipment, and care must be taken to ensure they are not overloaded.

» Air Filtration & Dust Extraction

The CuttingStation can be fitted with an air filtration or dust extraction system.

This is an optional extra, so please call 023 9238 0280 for more details.

» General Information

Lost Keys?

Replacement keys can be purchased from Armorgard, using the serial number on the product.

Spare Parts

Replacement parts are available for the following:

- rubber Mat
- castors
- electrical Components
- light
- swarf collector
- PVC Curtains
- locks
- support Arms
- fire rated, sound deadening foam
- extendable rear unit

ticking every box

View our full range of products online at
www.armorgard.co.uk



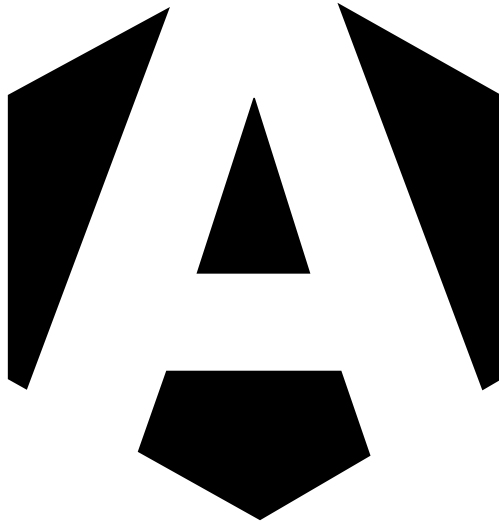

 **armorgard**
ticking every box.

Unit 14-16, Standard Way, Fareham Industrial Park, Fareham, Hampshire PO16 8XB
t: **023 9238 0280** e: **sales@armorgard.co.uk** w: **www.armorgard.co.uk**